



Centre Number	Candidate Number

**MINISTRY OF EDUCATION AND HUMAN RESOURCE DEVELOPMENT**

## **SOLOMON ISLANDS SCHOOL CERTIFICATE**

# **2018**

## **SOCIAL STUDIES**

**MONDAY 12<sup>TH</sup> NOVEMBER 9.00 AM**

**TIME: 3 Hours Plus 10 Minutes Reading Time.**

<u>SECTION</u>	<u>CONTENT</u>	<u>MARKS</u>	<u>TIME</u>
<b>A</b>	MULTIPLE CHOICE QUESTIONS	<b>30</b>	<b>30 Mins</b>
<b>B</b>	PROBLEM SOLVING AND EXTENDED WRITING QUESTIONS	<b>90</b>	<b>2½ Hrs</b>
	<b>TOTAL</b>	<b>120</b>	

### INSTRUCTIONS TO CANDIDATES

1. DO NOT OPEN THIS BOOKLET UNTIL YOU ARE TOLD TO DO SO.
2. WRITE BOTH YOUR CENTRE NUMBER AND CANDIDATE NUMBER IN THE BOX PROVIDED AT THE TOP RIGHT HAND CORNER AND THE BACK FLAP AT THE END OF THIS BOOKLET.
3. ALL SECTIONS AND QUESTIONS ARE COMPULSORY.
4. ALL QUESTIONS ARE TO BE ANSWERED ON THE SPACES PROVIDED IN THIS BOOKLET.
5. DO **NOT** USE CORRECTION FLUID.
6. MOBILE PHONES ARE **NOT** ALLOWED IN THE EXAMINATION ROOM.

**YOU MUST HAND THIS BOOKLET TO THE SUPERVISOR AT THE END OF THE EXAMINATION.**

**THIS BOOKLET CONTAIN 27 NUMBERED PAGES.**

**WRITE THE BEST CORRECT ANSWER IN THE BOX PROVIDED IN THE BACK FLAP PAGE.  
QUESTIONS (1 – 30) IS WORTH ONE (1) MARK EACH.**

-----

**Study the cartoon and answer questions (1, 2 and 3).**



1. Which TWO (2) **super powers** are shown on either side of the men fighting?
  - A. CHINA and USA.
  - B. USA and China.
  - C. USA and Soviet Union.
  - D. Soviet Union and China.
  
2. After World War 2, what was the official status of each of the **super powers** in relation to Korea?
  - A. USA administered North Korea after WWII while Russia administered South Korea after WWII.
  - B. USA administered North Korea after WWII while China administered South Korea after WWII.
  - C. Russia administered North Korea after World War II while USA administered South Korea after WWII.
  - D. Russia administered North Korea after WWI while USA administered South Korea after WWII.

3. What was the result of the Korean War and how did this affect the relationship between the TWO (2) super powers?
- A. USA contain communism while China contain fascism.
  - B. USA contain communism while USSR expand communism.
  - C. USSR adopted Capitalism while USA adopted communism.
  - D. USSR contain communism while China expand communism.

**Study the text below and answer questions (4 and 5) that follow.**

**LETTER FROM KRUSCHEV TO KENNEDY CONCERNING THE CUBAN CRISIS**

**“We and You ought not to pull on the ends of the rope** in which you have tied the knot of war, because the more the two of us pull, the tighter that knot will be tied and a moment may come when that knot will be tied too tight that even he who tied it will not have the strength to untie it... let us not only relax the forces pulling on the ends of the rope, let us take measures to untie that knot”.

*(Source: McWilliams, W and Piotrowski, H., The World Since 1945, A History of International Relations, 2005, p.103).*

4. What Kruschev meant by **“we and you ought not to pull on the ends of the rope”**, was;
- A. the rope might be too slippery that both could not hold on to it.
  - B. the two countries should relax the rope by not pulling it too tight.
  - C. War is inevitable and no one, even the one who started it, can prevent it from happening.
  - D. the two countries must stop arguing and showing off strength as both know the consequences.
5. The **knot** in the text refer to the;
- A. armistice.
  - B. imminent war.
  - C. argument between Russia and USA.
  - D. disarmament of nuclear weapons from both sides.

6. The **'League of Nations'** ceased its activities because;
- A. USA did not join the League.
  - B. it has failed to prevent WWII.
  - C. it has achieved peace and security before WWII.
  - D. all its members resigned and joined other international organisations.
7. The name **"United Nations"** was given by;
- A. Harry Truman.
  - B. John F Kennedy.
  - C. Wilson Churchill.
  - D. Franklin D. Roosevelt.
8. What is the main function of the **Trusteeship council**?
- A. The principal judicial organ of the United Nations.
  - B. For the maintenance of international peace and security.
  - C. To provide international supervision for 11 Trust Territories.
  - D. The principal body for coordination, policy review and policy dialogue.
9. The main aim of the **European Union organisation** is to;
- A. reaffirm faith in fundamental human rights.
  - B. save succeeding generations from scourge of terrorist attacks.
  - C. abolish the obstacles to the free movement of person, service and capital.
  - D. form a military Alliance of European countries with South Pacific Organisations.
10. The main function of the **Pacific Islands Forum Secretariat** is to;
- A. monitor the Islands Exclusive Economic Zone (EEZ).
  - B. strengthen national capacity and regional solidarity to its 17 members.
  - C. observe and help the region's premier political and economic policy organisation.
  - D. provide technical assistance, training and research services to 22 Pacific Island countries.

11. The Secretariat of the Pacific Regional Environment Programme [SPREP] is;
- a technical organisation that manage the tuna fisheries and its environment.
  - based in Suva to monitor the change in the environment affected by climate change.
  - established by the regional governments of the Pacific region to look after its environment.
  - a management of non-highly migratory fisheries and protection of biodiversity in the marine environment.
12. The **positive** impacts of migration to the losing country are:
- New development and brain drain.
  - Less labour force and less development.
  - Decrease of population and less competition.
  - More labour force and destruction of habitats.
13. Human beings bring about changes in the environment by?
- leaving the land undeveloped.
  - creating few employment opportunities.
  - allowing only human labour to work on the land.
  - developing their land for food and economic purposes.

**Study the graph on the rate of natural population increase in different regions of the world (2004). The average annual rate of natural increase for the world as a whole is 1.3%. Answer question 14 below.**

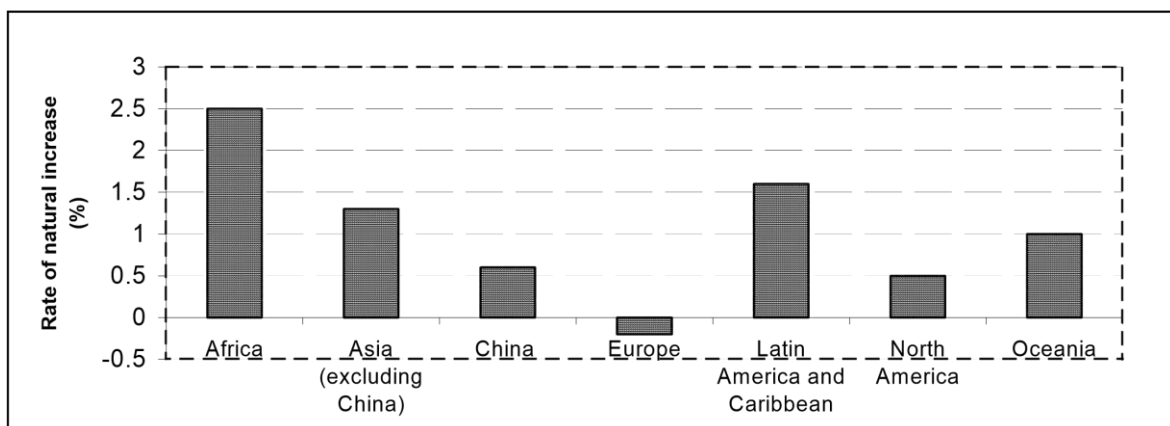

14. Which TWO (2) regions' rates of natural increase are higher than the world average?
- A. Africa and China.
  - B. Oceania and Asia.
  - C. Asia and Latin America.
  - D. Latin America and Africa.
15. What are the major causes of **population increase**?
- A. Increase in birth rate and increase in death rate.
  - B. Decrease in birth rate and decrease in death rate.
  - C. Increase in birth rate and decrease in death rate.
  - D. Decrease in birth rate and increase in death rate.
16. What are the major causes of **population decrease**?
- A. Increase in birth rate and increase in death rate.
  - B. Decrease in birth rate and decrease in death rate.
  - C. Increase in birth rate and decrease in death rate.
  - D. Decrease in birth rate and increase in death rate.
17. The **impact** of growing world population on water is that;
- A. the cost of water will be lower.
  - B. demand for water will increase.
  - C. there will be a lot of water supply.
  - D. there will be low demand of water.
18. What is ONE (1) main cause of food crops shortage in the **developed countries**?
- A. Natural disasters.
  - B. Lack of skilled man power.
  - C. High rate of unemployment.
  - D. Deficiency of nutrient and vitamins.
19. Factories during the **industrial revolution** in Europe, employed children and women because they were;
- A. cheaper source of labour.
  - B. not willing to join trade unions.
  - C. more skilled and efficient than men.
  - D. easier to train for using new technology.

20. Which system of transportation is more suitable in transporting **bulk goods** over long distances between Islands and continents?



A



B



C



D

21. The main reason for an industry **not** willing to move to new and more suitable location is because of the;

- A. High costs of moving.
- B. Lack of good industrial sites.
- C. High rents in industrial estates.
- D. Importance of original factors of location.

Study the graph below and answer questions (21 and 22).

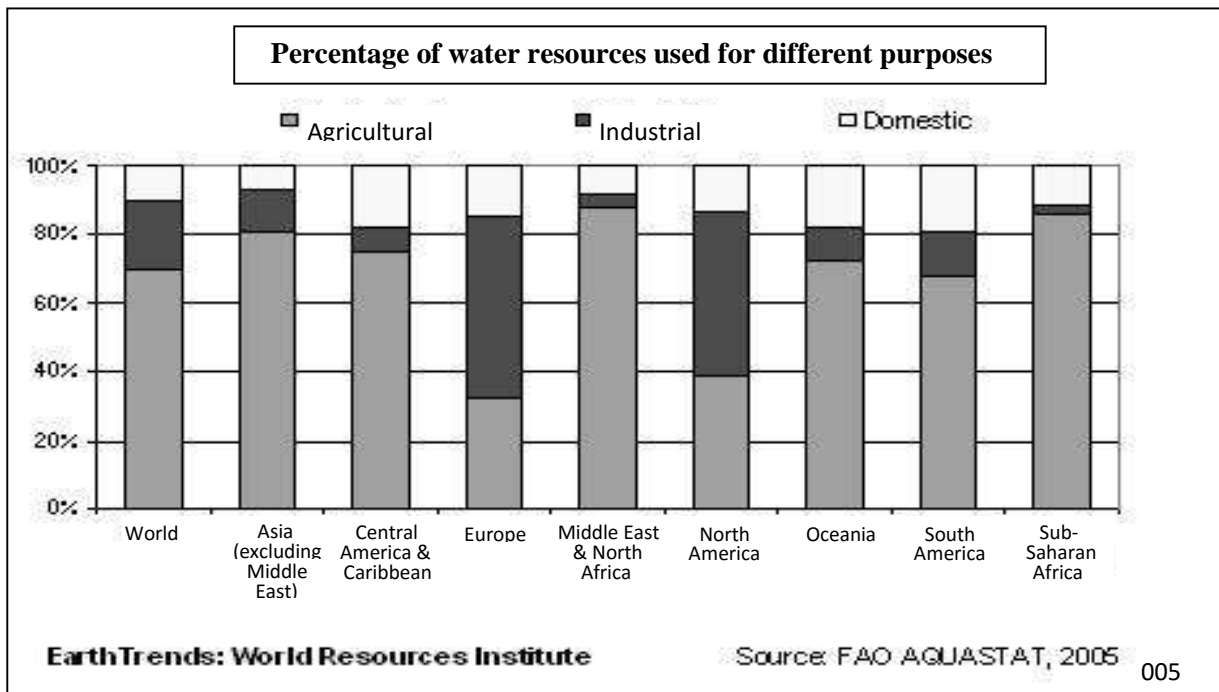

22. Which TWO (2) areas from the graph above where almost half of all fresh water resources are used for industrial purposes?

- A. EUROPE and Asia.
- B. Asia and South America.
- C. North America and Europe.
- D. South America and North America.

23. Identify TWO (2) areas from the graph above where more than 80% of fresh water resources are used for Agricultural purposes.

- A. Asia and Sub-Saharan Africa.
- B. Oceania and Central America.
- C. Middle East& North Africa and Oceania.
- D. Sub-Saharan Africa and Middle East & North Africa.



24. Study the pictures below and identify which one is a hamlet.



A



B



C



D

25. In traditional Solomon Island Societies, **Big Men** gained power and authority by;

- A. inheritance.
- B. a voting system.
- C. hard work and ownership of wealth.
- D. raising their hands in a community meeting.

26. The **main driving force** for labour trade in Queensland in the mid-19<sup>th</sup> Century was that;

- A. Western World still strongly accentuated the systems of slavery.
- B. a project of this type to succeed, a large amount of labour would be required.
- C. demand for cheap labour accustomed to working in the harsh sub-tropical climates.
- D. more labourers means bigger plantations to produce more yield, thus more money.

27. Which of the following was **true** about labour trade in the Solomon Islands?

- A. All labourers were captured and forced to work.
- B. Many young men volunteered to go to Queensland.
- C. All labourers who went to Queensland never returned.
- D. There were more women than men who went to Queensland.

28. The high dependency on imported processed food is because of the;
- A. people's land became unfertile.
  - B. economic system of the country.
  - C. local food became very expensive.
  - D. dependency on foreign economy.
29. The main aim of the Missionaries as an **Agent of Change** was to;
- A. convert heathens to Christianity.
  - B. help provide better trading system.
  - C. assist in build proper church buildings.
  - D. help build schools, clinics and plantations.
30. What **Economic benefit** that labour Trade brought to our Islands?
- A. Intermarriage and migration between the Islands.
  - B. Maintain traditional Agricultural and farming practices.
  - C. Labourers returned with axes, knives, clothes and tobacco.
  - D. Establishment of the Christian Churches in Solomon Islands.

**Total marks for Section A: 1-30**

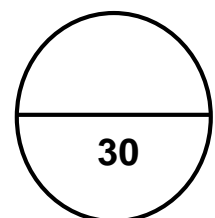

**SECTION B: PROBLEM SOLVING AND EXTENDED WRITING**

**[90 MARKS]**

**1.0 CONFLICT AND COOPERATION**

**CONFLICT**

**[15 MARKS]**

**PART 1: PROBLEM SOLVING**

**[11 Marks]**

Study the resource below and answer questions (i – v).

**March against Vietnam War**



March in San Francisco was one of thousands that took place all over the world in the mid to late 1960's. (Source: Heater. D, *Our World this Century*, 1997. P.104).

i. What year did the Vietnam War started?

\_\_\_\_\_ (1 mark)

ii. State TWO (2) reasons why America was involved in this war.

(a) \_\_\_\_\_ (1 mark)

(b) \_\_\_\_\_ (1 mark)

iii. Provide TWO (2) evidences from the photograph above that showed how Americans opposed this war.

(a) \_\_\_\_\_ (1 mark)

(b) \_\_\_\_\_ (1 mark)

iv. Name the American President during the time of this war and explain ONE (1) of his Act after the demonstration.

Name of President: \_\_\_\_\_ (1 mark)

Act: \_\_\_\_\_  
\_\_\_\_\_  
\_\_\_\_\_  
(2 marks)

v. Discuss Economic consequences of this war on the American people.

\_\_\_\_\_  
\_\_\_\_\_  
\_\_\_\_\_  
\_\_\_\_\_  
\_\_\_\_\_  
(3 marks)



**1.0 CONFLICT AND COOPERATION**

**COOPERATION**

**[18 MARKS]**

**PART 1: PROBLEM SOLVING**

**[14 Marks]**

**A. READ THE STATEMENT BELOW TO ANSWER QUESTIONS (1 AND 2).**

Number of specialised Agencies are directed/aimed to promote economic growth of developing countries, including Solomon Islands, supporting human rights and fostering world cooperation to fight poverty and under-development. Around 70% of United Nation system is devoted to this. Under one of the Six Organs of the United Nation, is the Economic and Social Council (ECOSOC), responsible for coordinating the economic and social work of the United Nations and its system.

1. Based on human rights,

(a) Provide TWO (2) challenges faced by our Government towards achieving this aim?

(i) \_\_\_\_\_  
\_\_\_\_\_  
\_\_\_\_\_

(ii) \_\_\_\_\_  
\_\_\_\_\_  
\_\_\_\_\_

(2 marks)

(b) If you are a national leader, provide ONE (1) way to address the above challenges.

\_\_\_\_\_  
\_\_\_\_\_  
\_\_\_\_\_

(2 marks)

2. The TWO (2) main Agencies of United Nation in Solomon Islands are UNICEF and UNDP. Discuss their main roles and functions in relation to the above statement.

(a) UNICEF: \_\_\_\_\_

---

---

---

(3 marks)

(b) UNDP: \_\_\_\_\_

---

---

---

(3 marks)





2.0 INDUSTRIALIZATION/URBANIZATION

[17 MARKS]

PART 1: PROBLEM SOLVING

[7 marks]

1. Study the Charts below and answer questions (i and ii).

World Urbanization, 1950, 2000, and 2050.

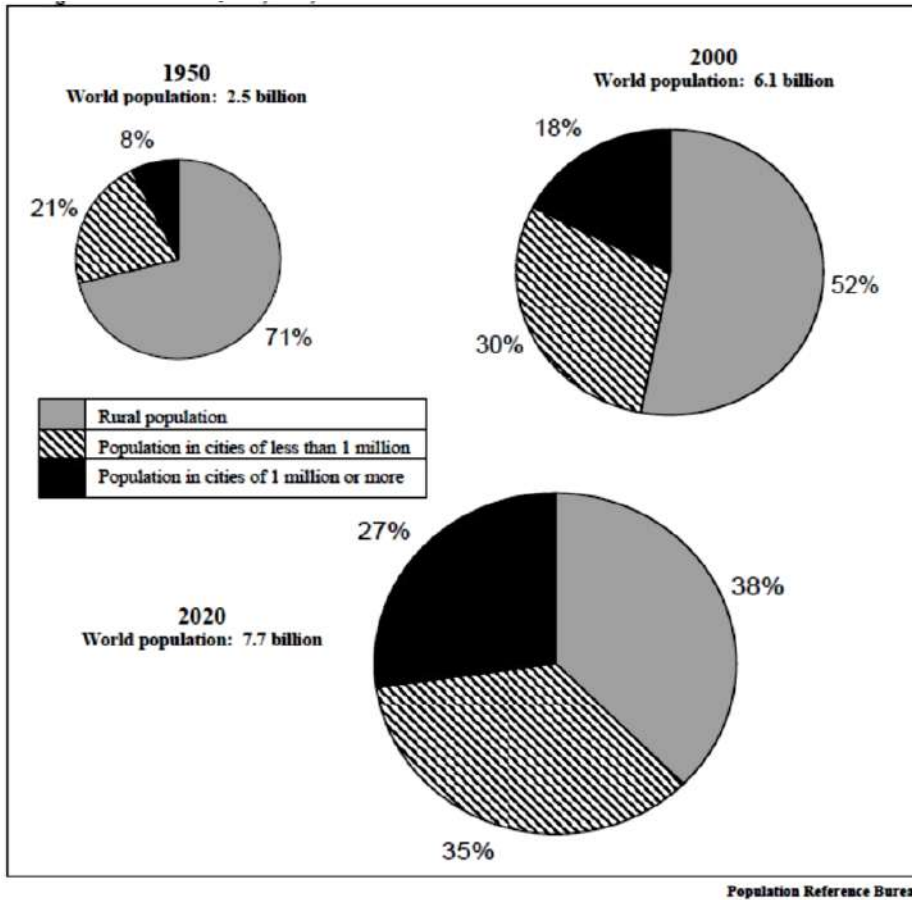

Provide statistical evidence from above figure to show that world urbanization is **increasing**. Explain ONE (1) reason for the increase.

---

---

---

---

(2 marks)

- I. Calculate the number of people who were living in millionaire cities (megacities) in the year 2000.

---

---

---

---

(2 marks)

2. Complete the key below by writing the correct zone for number 5.

KEY

- 1. CBD
- 2. Factory/Wholesale
- 3. Low class residential
- 4. Medium Class Residential
- 5. \_\_\_\_\_

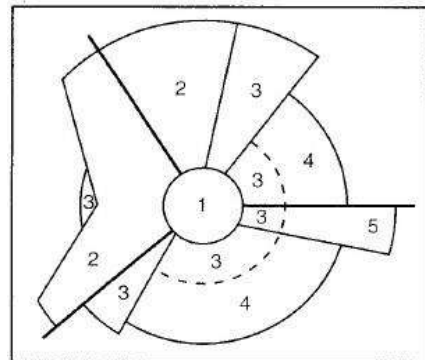

(1 mark)

Describe ONE (1) type of land-use within the Factory/Wholesale?

---

---

---

---

(2 marks)

URBAN PROBLEM

Study picture below and answer question 3 (a and b).



3. In the picture above, describe TWO (2) measures that have been taken to overcome this problem in urban areas.

(a) \_\_\_\_\_  
\_\_\_\_\_  
\_\_\_\_\_

(2 marks)

(b) \_\_\_\_\_  
\_\_\_\_\_  
\_\_\_\_\_

(2 marks)

**4. EFFECTS OF URBAN GROWTH**

**Identify TWO (2) common problems that Honiara city experience, and explain how the city planners will manage the problems to reduce their negative implications.**

TWO (2) common problems:

(i) Problem \_\_\_\_\_ (1 mark)

How to solve the problem;

---

---

---

(2 marks)

(ii) Problem \_\_\_\_\_ (1 mark)

How to solve the problem;

---

---

---

(2 marks)

**PART 1: PROBLEM SOLVING**

[8 marks]

**Climate change** has become a contemporary environmental issue of the modern era as it is now a major threat to our planet Earth. Its visible impacts are experienced in the small islands of the South Pacific including Solomon Islands. Not only does it affect people’s activities, it has also contributed to mass population distribution.

**A. Study the picture below that shows the relationship between human activities and climate change.**

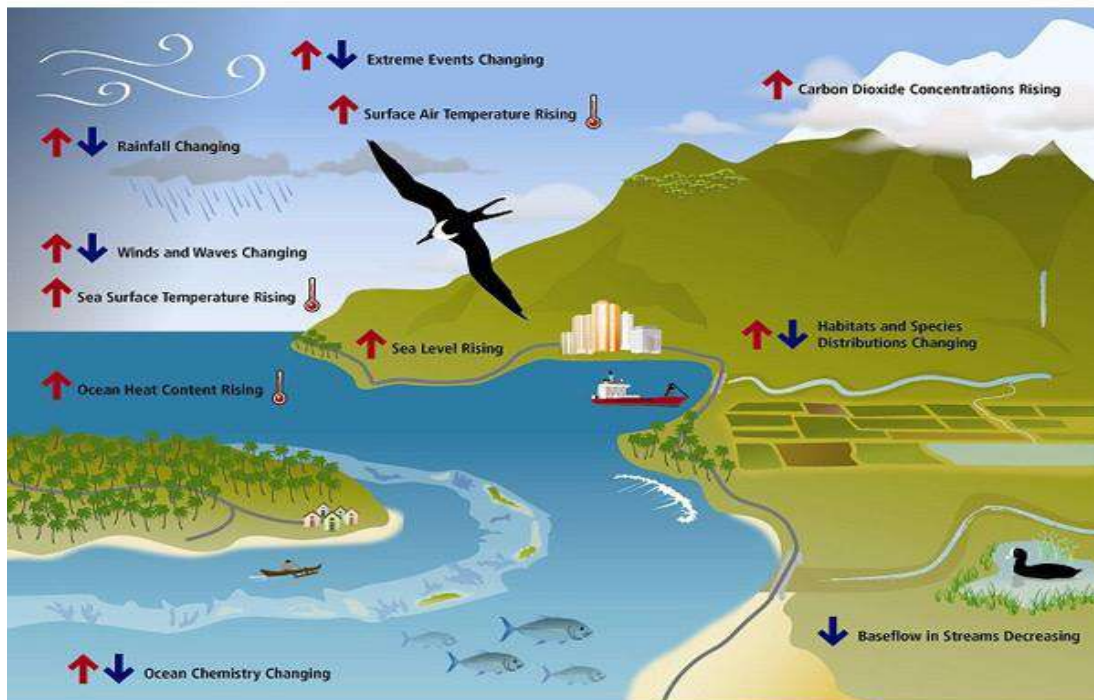

Key indicators of climate change in the Pacific Islands region. From: *Climate Change and Pacific Islands: Indicators and Impacts*, Pacific Islands Regional Climate Assessment, 2012

**Using your own knowledge with the above information, explain how the following human activities affect climate.**

1. Air Pollution:

---



---



---

(2 marks)

2. Deforestation:

---



---



---

(2 marks)



(b) \_\_\_\_\_  
\_\_\_\_\_  
\_\_\_\_\_  
\_\_\_\_\_  
\_\_\_\_\_  
\_\_\_\_\_  
\_\_\_\_\_  
\_\_\_\_\_  
\_\_\_\_\_  
\_\_\_\_\_

(3 marks)

Describe any TWO (2) effects of climate change on population distribution:

(a) \_\_\_\_\_  
\_\_\_\_\_  
\_\_\_\_\_  
\_\_\_\_\_

(2 marks)

(b) \_\_\_\_\_  
\_\_\_\_\_  
\_\_\_\_\_  
\_\_\_\_\_

(2 marks)

**4.0 CHANGE AND CONTINUITY**

**[22 MARKS]**

**PART 1: PROBLEM SOLVING**

**[15 marks]**

**Study the Map of the Pacific below and answer question 1 (i and ii). [6 marks]**

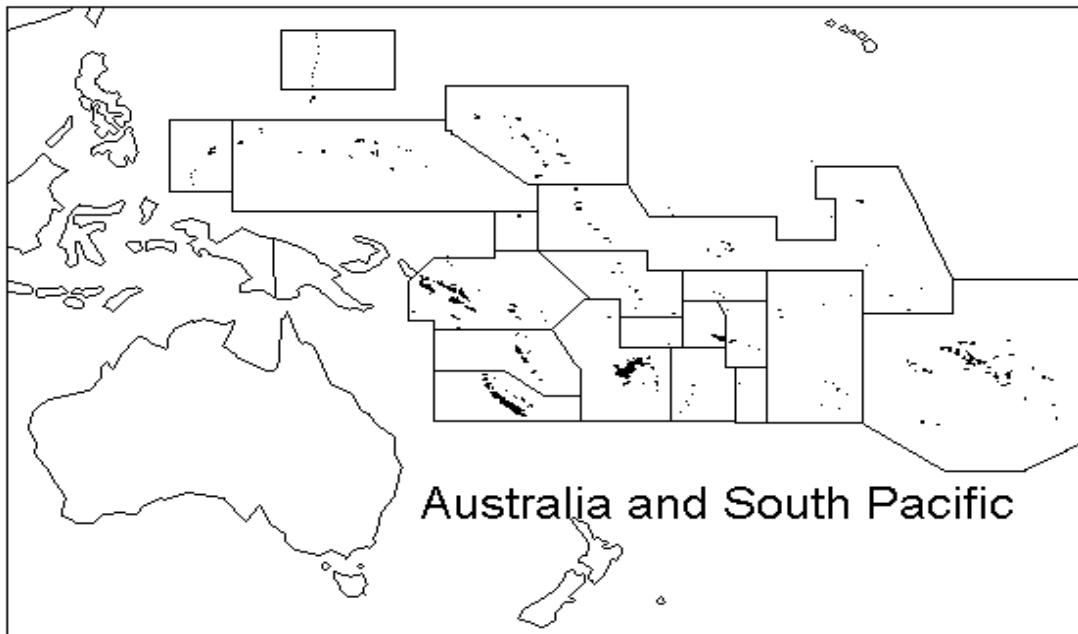

1) (i) Indicate by a tick (✓) on the Map above:

a. TWO (2) Melanesian countries: (2 marks)

(ii) From the map above, name:

b. TWO (2) Polynesian countries:

(i) \_\_\_\_\_, (ii) \_\_\_\_\_, (2 marks)

c. TWO (2) Micronesian countries:

(i) \_\_\_\_\_

(ii) \_\_\_\_\_

(2 marks)



d. Identify ONE (1) way early Pacific Islanders were able to pass on knowledge and skills from one generation to the next without written tradition.

(i) \_\_\_\_\_  
(1 mark)

e. Name the Explorer that **first** cross the Pacific Ocean and in what year?

(i) Name: \_\_\_\_\_ (1 mark)

(ii) Year: \_\_\_\_\_ (1 mark)

f. State TWO (2) reasons that motivated the expansion into the Pacific Islands.

(i) \_\_\_\_\_  
(1 mark)

(ii) \_\_\_\_\_  
(1 mark)

g. Identify TWO (2) problems faced by **early explorers** as they navigated the Pacific Islands.

(i) \_\_\_\_\_  
(1 mark)

(ii) \_\_\_\_\_  
(1 mark)

h. State ONE (1) positive and ONE (1) negative **influence** of traders among island communities.

(i) Positive: \_\_\_\_\_  
(1 mark)

(ii) Negative: \_\_\_\_\_  
(1 mark)

**PART 2: EXTENDED WRITING**

**[7 marks]**

1. Provide evidences with your justifications to the meaning of the phrase  
**“Europeans are generally portrayed as actors and islanders as the acted upon...”**

---

---

---

---

---

---

---

---

---

---

(3 marks)

2. The missionaries also established **education** and **health** as way forward to growth of society. Explain how these two (2) changes impacted island societies and their way of life today.

(i) Education

---

---

---

---

(2 marks)

(ii) Health

---

---

---

---

(2 marks)

**Total marks for Section B: 1.0 – 4.0**

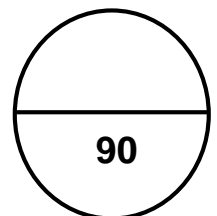

# SISC – SOCIAL STUDIES 2018

CANDIDATE NUMBER					CENTRE NUMBER		
<input type="text"/>	<input type="text"/>	<input type="text"/>	<input type="text"/>	<input type="text"/>	<input type="text"/>	<input type="text"/>	<input type="text"/>

## SECTION A: MULTIPLE CHOICE (30 MARKS)

Write the letter of the correct answer in the box provided.

**Example:** If you consider A is the correct answer, write it like this:

To change your answer From A to C,  c

1	<input type="text"/>	16	<input type="text"/>
2	<input type="text"/>	17	<input type="text"/>
3	<input type="text"/>	18	<input type="text"/>
4	<input type="text"/>	19	<input type="text"/>
5	<input type="text"/>	20	<input type="text"/>
6	<input type="text"/>	21	<input type="text"/>
7	<input type="text"/>	22	<input type="text"/>
8	<input type="text"/>	23	<input type="text"/>
9	<input type="text"/>	24	<input type="text"/>
10	<input type="text"/>	25	<input type="text"/>
11	<input type="text"/>	26	<input type="text"/>
12	<input type="text"/>	27	<input type="text"/>
13	<input type="text"/>	28	<input type="text"/>
14	<input type="text"/>	29	<input type="text"/>
15	<input type="text"/>	30	<input type="text"/>

## FOR MARKER USE ONLY

SECTION	MARKS	MARKER	SCRIPT CHECKER
A	30		
B	90		
<b>TOTAL</b>	<b>120</b>		
Marker/ Checker Initials			